

# J. BROWNING. KNURLING MACHINE.

No. 554,811.

Patented Feb. 18, 1896.

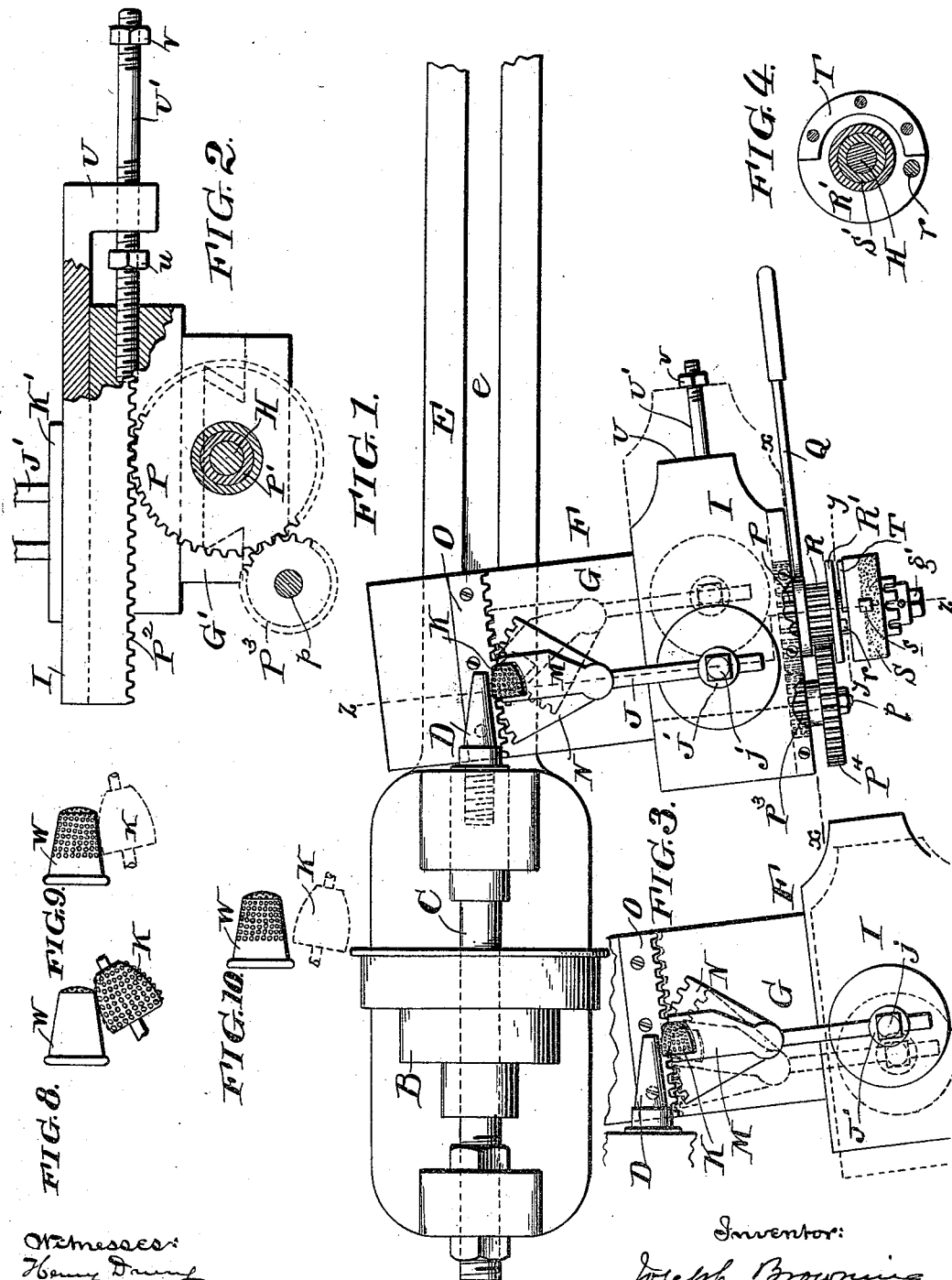

Witnesses:  
 Harry Dunning  
 A. A. Bitterlich

Inventor:  
 Joseph Browning  
 My law attorney  
 [Signature]

(No Model.)

2 Sheets—Sheet 2.

# J. BROWNING. KNURLING MACHINE.

No. 554,811.

Patented Feb. 18, 1896.

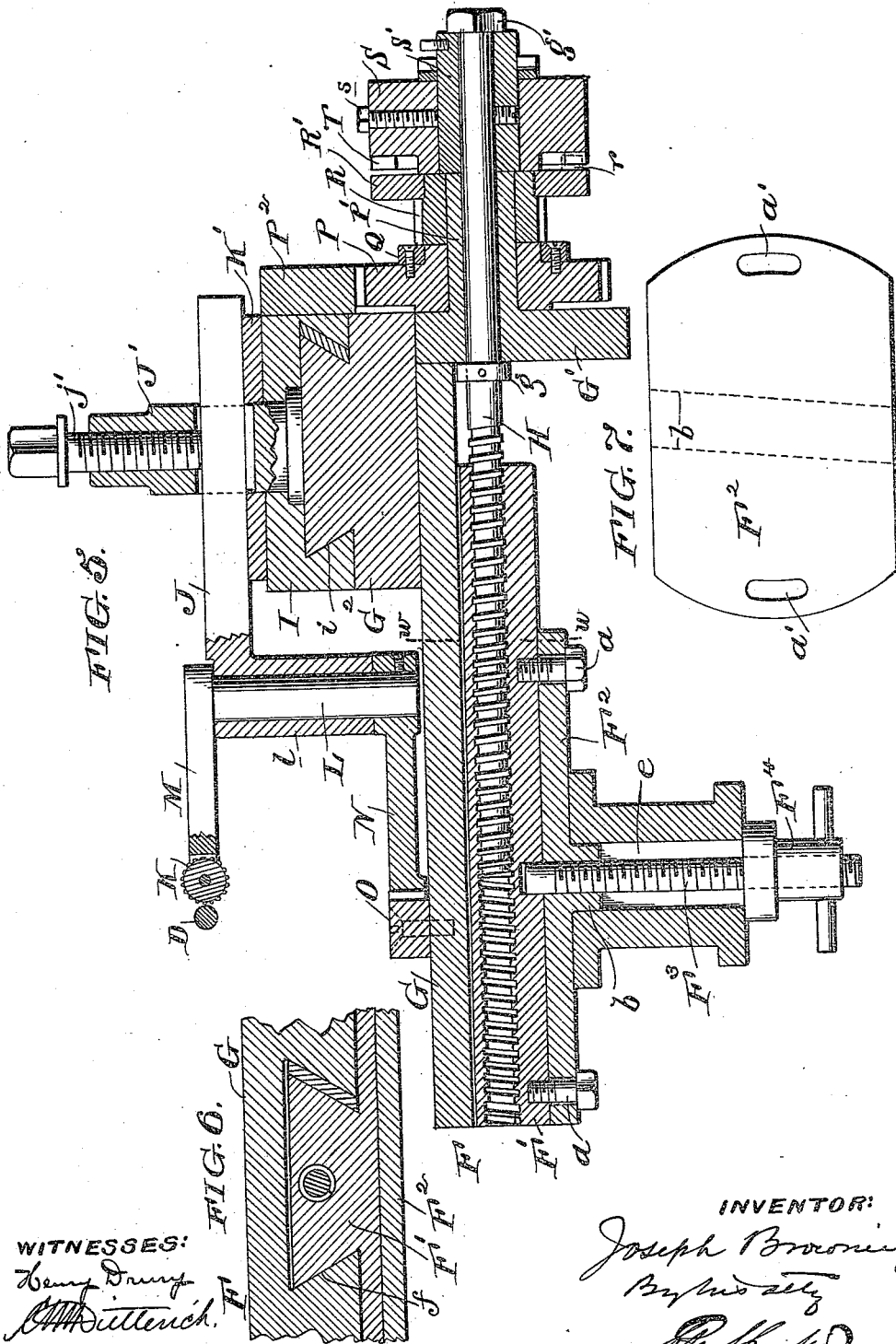

WITNESSES:  
*Henry Dancy*  
*Wm. Dittlerich*

INVENTOR:  
*Joseph Browning*  
*By* *Wm. Dancy*  
*Wm. Dancy*

# UNITED STATES PATENT OFFICE.

JOSEPH BROWNING, OF PHILADELPHIA, PENNSYLVANIA, ASSIGNOR TO  
SIMONS, BROTHER & CO., OF SAME PLACE.

## KNURLING-MACHINE.

SPECIFICATION forming part of Letters Patent No. 554,811, dated February 18, 1896.

- Application filed January 4, 1893. Serial No. 457,256. (No model.)

*To all whom it may concern:*

Be it known that I, JOSEPH BROWNING, of the city and county of Philadelphia and State of Pennsylvania, have invented an Improvement in Knurling-Machines, of which the following is a specification.

My invention relates to knurling-machines; and it consists of certain improvements, which are fully set forth in the following specification and shown in the accompanying drawings, which form a part thereof.

My invention is particularly designed for knurling thimbles, though it may be used for other articles.

The present invention is designed for knurling the conical surface of the thimble only, and is not concerned with the knurling of the top. For the latter purpose I have invented another machine, which forms no part of the present invention.

The usual method employed for knurling thimbles consists in rotating the thimble-blank upon the mandrel of a lathe and holding a hand-tool in contact with the rotating surface. This requires the exercise of great skill upon the part of the operator.

It has been difficult to knurl thimbles by machinery, owing to the conical shape of the surface to be knurled, since the knurling-tool must have imparted to it movements corresponding to the varying diameter of the thimble.

It is the object of my invention to produce a machine capable of knurling thimbles and other articles of a similar shape as efficiently as the operation is now accomplished by the skilled laborer with a hand-tool and also to make the machine capable of adjustment for the different sizes of thimbles and for the depth of surface to be knurled.

In carrying out my invention I employ a rotary mandrel to support the thimble and a knurling-tool carried by a sliding frame having a compound movement by which the necessary movements are imparted to the tool when it is brought in contact with the surface to be operated upon. The movement of the knurling-tool is controlled by a lever or handle for the operation of which skilled labor is not required. By the simple operation of

this handle or lever the tool is brought in contact with the surface to be knurled, is moved in contact with that surface to the extent to which the knurling is to be applied, and is then retracted from the thimble and returned to its first position ready for operation upon the next thimble. The knurled thimble is meanwhile removed and is replaced by another thimble-blank when the operation is repeated as before.

The machine may be easily adjusted, not only to suit the size of the thimbles to be operated upon, but also to suit the depth of the knurling desired.

I shall now refer to the drawings for the purpose of describing the construction and mode of operation of my improved knurling-machine.

In the drawings, Figure 1 is a plan view of my improved knurling-machine. Fig. 2 is a longitudinal vertical sectional view of the same on the line *xx* of Fig. 1. Fig. 3 is a plan view of a portion of the machine, illustrating the operation. Fig. 4 is a vertical sectional view on the line *yy* of Fig. 1. Fig. 5 is a transverse vertical sectional view of the machine on an enlarged scale, taken on the line *zz* of Fig. 1. Fig. 6 is a vertical sectional view on the line *ww* of Fig. 5. Fig. 7 is a plan view of the base-plate of the movable carriage which carries the knurling-tool; and Figs. 8, 9, and 10 are illustrating views showing the operation of the knurling-tool on a thimble.

A is the stationary frame of the machine. B is a lathe-spindle and pulley mounted thereon.

D is the mandrel, which supports the thimble or object to be operated upon, carried by the spindle C of the lathe. The mandrel may be detachably connected with the spindle C, so that one mandrel may be removed and replaced by another to suit the size of the thimble or object to be operated upon.

K is the knurling-tool, which is preferably conical in shape with a slightly convex surface.

F is a movable carriage, which carries the knurling-tool K. The carriage F is arranged transversely to the mandrel D.

E is a longitudinal guide-frame in which the carriage F may be moved longitudinally for purposes of adjustment.

The movable carriage F is provided with a sliding portion G movable longitudinally on the base of the carriage, and also with a sliding portion I movable transversely upon the slide G. The knurling-tool K is carried by the sliding portion I and is operated by the movement thereof and also by the movement of the sliding portion G, as will be more fully described hereinafter.

F' is the lower portion of the carriage F and is provided with a guide *f*, Fig. 5, upon which the slide G moves.

F<sup>2</sup> is a base-plate connected with the part F' by screws *a* passing through slots *a'* and provided upon its lower surface with a rib *b*, by which it is guided in the longitudinal groove or slot *e* of the guide-frame E.

F<sup>3</sup> is a clamping-screw passing through the slot *e* of the guide E into the base of the carriage F and provided with a nut F<sup>4</sup>, by which the carriage F may be clamped in any position in the length of the guide E.

G' is an end frame piece carried by the outer end of the slide G, through which an adjusting-screw H extends into the threaded bore *h* of the base-frame F'. The screw is held against longitudinal movement in the frame G' by the nuts *g g'*. It is apparent that any turning of this adjusting-screw H will cause the slide G to move longitudinally upon the base portion F' of the carriage F.

G<sup>2</sup> is a guide-piece upon the outer end of the slide G, provided with transverse guides *i* upon which the transversely-movable slide I is guided.

J is an arm carried by a slide J' located on the slide I and clamped therein by a set-screw *j*.

K' is a plate resting on the upper surface of the slide I and surrounding the stud J', upon which the arm J is clamped by the screw *j*. (See Fig. 5.) By this means the arm may be adjusted either vertically or horizontally in the stud J', the aperture in the stud through which the arm J passes being of sufficient height to permit a vertical adjustment. In making such an adjustment the plate or washer K' will be changed accordingly.

L is a shaft journaled in a bearing *l* in the end of the arm J, by the upper end of which is carried an arm M, in which the knurling-tool K is loosely journaled.

N is a toothed segment carried by the lower end of the shaft L.

O is a toothed rack carried by the slide G and arranged transversely thereon, with which the toothed segment N engages.

P is a gear-wheel loosely journaled upon a sleeve P' of the end frame-piece G'.

P<sup>2</sup> is a toothed rack carried by the slide I with which the toothed gear-wheel P engages.

Q is a lever connected with the gear-wheel P, by which the gear-wheel may be turned to

move the slide I transversely upon the slide G through the gear-wheel P and rack P<sup>2</sup>.

P<sup>3</sup> is a pinion carried on a stud *p* on the frame-piece G', engaging with the gear-wheel P.

P<sup>4</sup> is a gear-wheel carried on a common sleeve with the pinion P<sup>4</sup>, so as to rotate therewith.

R is a pinion loosely journaled on the sleeve P' and engaging with the gear-wheel P<sup>4</sup>, so as to be driven thereby.

It will be seen that any movement of the lever Q to move the slide I through the rack P<sup>2</sup> will rotate the pinion R through the intermediate gears P<sup>3</sup> and P<sup>4</sup>.

R' is a disk carried by the pinion R and provided with a pin or lug *r*.

S is a collar carried on a sleeve S', fast upon the end of the adjusting-screw H. The collar S is made fast to the sleeve S' and screw H by a set-screw *s*.

T is a partly-circular plate carried by the inner side of the collar S, adjacent to the disk R' and adapted to be struck by the lug or pin *r* thereof.

U, Figs. 1 and 2, is an overhanging arm carried by the slide I.

U' is a rod carried by the guide-piece G<sup>2</sup> and extending through the arm U, so that the arm U will reciprocate upon the rod U' during the movements of the slide I. The rod U' is provided with adjustable stops *u* and *v* for the arm U, which thus acts to limit the movement of the slide I in either direction. By adjusting the stops *u* and *v* the extent of the movements of the slide I may be regulated.

W is the thimble or other object to be operated upon.

Having now explained the construction of my machine as illustrated in the drawings, I will describe the mode of operation.

The blank thimble or other object to be knurled is placed upon the mandrel D, which is rapidly rotated by the lathe B. The slide I is in its extreme position away from the mandrel, as is shown in dotted lines in Fig. 1, and the knurling-tool is retracted from the mandrel and the blank thereon. The lever Q is operated, turning the gear-wheel P and feeding the slide I forward through the rack P<sup>2</sup>. As the slide I moves forward, the arm J is carried with it, and the segment N moves in the rack O, rocking the shaft L and arm M correspondingly. This movement of the arm M carries the knurling-tool K in contact with the surface of the thimble, as is shown in Fig. 7. In this position the knurling-tool is at an angle to the axis of the mandrel (see Fig. 8) and one portion of its surface only is in contact with the upper portion of the surface to be ornamented and imparts ornamentation to that portion of the surface only. For ordinary work the portion of the knurl which first comes in contact with the thimble is slightly below the

extreme end of the knurl, as is shown in Fig. 8. This depends, however, on the depth of the knurled surface to be produced. As the slide I continues to move forward the segment N is rocked by the stationary rack O and the arm M is correspondingly rocked, so that the obliquity of the knurling-tool to the axis of the mandrel is gradually changed and the successive portions of the tool are brought in contact with successive portions of the surface of the thimble, as is shown in Fig. 9. By this means the knurling-surfaces of the tool are brought successively in contact with the surface of the thimble and the thimble is knurled to the depth desired. Fig. 9 shows the position of the knurling-tool just before the completion of the operation. At this moment, however, the slide I has not reached the limit of its forward movement. During this movement of the slide I the pinion R has been rotated part of a revolution through the gears P, P<sup>3</sup>, and P<sup>4</sup>, and at the moment when the knurling operation has been completed, as has just been described, the pin r upon the disk R' carried by the pinion R strikes the end of the plate T on the collar S and rotates the collar S for the remainder of the forward movement of the slide I. As the collar S is fast upon the screw H, the screw H is rotated with it and the sliding frame G is drawn back upon the frame F', carrying with it the transversely-moving slide I and the knurling-tool K, which is thus moved away from the thimble. This last movement is shown in dotted lines in Fig. 3, and the position of the knurling-tool K with reference to the thimble is shown in Fig. 10. The knurled thimble may now be removed and another blank may be placed upon the mandrel. The handle or lever Q is now moved in the opposite direction, which turns the gear P backward and moves the slide I back. When this operation is begun there is no movement of the slide F, since the pin r of the disk R' is moving back away from the end of the plate T on the collar S; but when the slide I has almost reached the limit of its backward reciprocation the pin r strikes the other end of the plate T and turns the screw H back, returning the slide F to its former position and bringing the tool K in operative position to act upon the new thimble-blank. The operation is then repeated as has been described.

It is apparent that instead of a single plate T upon the collar S two small projections or lugs might be used.

It will be seen that the knurling-tool K has imparted to it, while acting upon the metal, a movement in the arc of a circle, produced by the reciprocation of the slide I, and this movement causes the successive portions of the tool to come in contact with the successive portions of the surface to be ornamented, the circumference of the tool increasing with the circumference of the thimble.

The automatic retraction of the tool after

the completion of the knurling operation permits the removal of the knurled thimble and the substitution of a blank.

I have now described the mode of operation of the machine when adjusted for thimbles or objects of a given size. I shall now describe the manner in which the machine may be adjusted for different sizes of thimbles and for different depths of knurling. As has been hereinbefore explained, the mandrel may be removed and may be replaced by another suited to the size of the thimble.

Through the collar S the screw H may be turned to move the slide F, and with it the slide I and knurling-tool K, nearer to the axis of the mandrel or farther from it. In making this adjustment the collar S may be first loosened and moved outward, so as to bring the plate T out of the path of the pin r. It may then be tightened and the screw H adjusted, and may finally be moved back into proper position to be operated upon by the pin r and made fast. The collar S is capable of rotary adjustment on its sleeve S', so that the plate T may be brought into the exact position at which it is desired to stop the knurling operation and retract the tool.

By the adjustment of the stops u and v the amount of movement of the slide I may be regulated.

The depth of the knurled surface of the thimble is controlled by the portion of the knurl which first comes in contact with the conical surface, since in operation the surface of the tool from that point to the end moves over the surface of the thimble. This is clearly shown in Figs. 8, 9, and 10. To increase the depth of the surface knurled, it is necessary, therefore, to adjust the machine so that the portion of the tool which first comes in contact with the metal will be higher up or nearer the top of the tool. This may be accomplished by moving the entire carriage farther out upon the guide-frame E. By this longitudinal adjustment of the carriage upon the guide-frame E the depth of the knurling may be regulated.

While I prefer the minor details of construction that have been shown, I do not limit myself to them, as it is apparent that they may be varied without departing from the invention.

What I claim as new, and desire to secure by Letters Patent, is—

1. In a knurling-machine the combination of a rotating mandrel to support the object to be knurled, a sliding frame movable transversely to and from the axis of the mandrel, a second sliding frame movable transversely on the first sliding frame, a knurling-tool carried by the second sliding frame, and means to move the knurling-tool in the arc of a circle during the reciprocation of the second sliding frame on the first.

2. In a knurling-machine the combination of a rotating mandrel to support the object to be knurled, a sliding frame movable trans-

versely to and from the axis of the mandrel, a second sliding frame movable transversely on the first sliding frame, a knurling-tool carried by the second sliding frame, a toothed rack carried by the first sliding frame, and a toothed segment carried by the knurling-tool and engaging with the rack whereby the knurling-tool is rocked in the arc of a circle during the reciprocation of the second sliding frame on the first.

3. In a knurling-machine the combination of a rotating mandrel to support the object to be knurled, a sliding frame, movable transversely to and from the axis of the mandrel, a second sliding frame movable transversely on the first sliding frame, a knurling-tool carried by the second sliding frame, means to move the knurling-tool in the arc of a circle during the reciprocation of the second sliding frame on the first, and power connections between the two sliding frames to reciprocate the first sliding frame intermittently.

4. In a knurling-machine, the combination of a rotating mandrel to support the object to be knurled, a sliding frame arranged transversely to the axis of the mandrel, a second sliding frame carried by the first and movable transversely thereon, a knurling-tool carried by the second sliding frame, gearing between the two frames to rock the knurling-tool in the arc of a circle during the reciprocation of the second frame on the first, devices to move the first frame transversely to the axis of the mandrel, and intermittently operating connections between the second frame and the devices for moving the first frame whereby the latter is reciprocated intermittently.

5. In a knurling-machine, the combination with a rotating mandrel to support the object to be knurled, of a rocking tool-holder having an independent longitudinal movement with reference to the axis of the mandrel, and a knurling-tool carried by the tool-holder.

6. In a knurling-machine, the combination of a rotating mandrel to support the object to be knurled, a reciprocating slide movable longitudinally with reference to the mandrel, a rock-shaft carried by the slide, a knurling-tool carried by the rock-shaft, a segment carried by the rock-shaft, and a stationary rack engaging with the segment.

7. In a knurling-machine, the combination of a rotating mandrel to support the article to be knurled, a frame arranged transversely thereto, a slide-frame carried by the first frame and movable longitudinally thereon, a feed-screw for moving said slide on its frame, a second slide carried by the first and movable transversely thereon, a knurling-tool carried by the second slide on a vertical axis, mechanism to swing the knurling-tool on its axis, and connections between the second slide and feeding-screw whereby the feed-screw is operated intermittently by the transverse reciprocation of the second slide on the

first to move the first slide on its frame to and from the axis of the mandrel.

8. In a knurling-machine, the combination of a rotating mandrel to support the object to be knurled, a reciprocating slide-frame movable longitudinally with reference to the axis of the mandrel, and a rocking tool-holder and knurling-tool carried by the reciprocating slide-frame.

9. In a knurling-machine, the combination of a mandrel to support the object to be knurled, a fixed frame arranged transversely thereto, a slide movable longitudinally on the fixed frame, a second slide movable transversely on the first, a rocking knurling-tool carried by the second slide, power devices for reciprocating the second frame transversely on the first, a feed-screw between the first slide-frame and the fixed frame, projecting parts carried by the feed-screw a rotary disk provided with a projection arranged in the path of the projecting parts of the feed-screw, and gearing connections between the second sliding frame and rotary disk.

10. In a knurling-machine, the combination of a mandrel to support the object to be knurled, a fixed frame arranged transversely thereto, a slide movable longitudinally on the fixed frame, a second slide movable transversely on the first, a rocking knurling-tool carried by the second slide, power devices for reciprocating the second frame transversely on the first, a feed-screw between the first slide-frame and the fixed frame, an adjustable collar carried by the end of the feed-screw provided with projecting parts, a pinion arranged adjacent to the collar on the feed-screw carrying with it a projection adapted to strike the projecting parts of the feed-screw, power devices to reciprocate the second slide transversely on the first, a toothed rack carried by the second slide, and gearing between the rack and pinion adjacent to the collar on the feed-screw.

11. In a knurling-machine, the combination with a rotary mandrel to support the object to be knurled, of a reciprocating slide movable longitudinally with reference to the axis of the mandrel, an arm J carried by the slide, a rock-shaft L journaled in the end thereof, a tool-holder M carried by the rock-shaft, a knurling-tool *k* carried by the tool-holder, a toothed segment N carried by the rock-shaft and a stationary toothed rack O engaging the segment N.

12. In a knurling-machine the combination with a rotary mandrel to support the object to be knurled, of a reciprocating slide movable longitudinally with reference to the axis of the mandrel, an arm J carried by the slide, a rock-shaft L journaled in the end thereof, a tool-holder M carried by the rock-shaft, a knurling-tool *k* carried by the tool-holder, a toothed segment N carried by the rock-shaft, a stationary toothed rack O engaging the segment N, a slide G arranged trans-

5 versely to the axis of the mandrel and carrying the longitudinally-reciprocating slide, and power-transmitting connections between the two slides whereby the slide G is moved trans-  
10 versely to the axis of the mandrel during a portion of the reciprocation of the other slide thereon.

13. In a knurling-machine the combination of a rotary mandrel to support the object  
10 to be knurled, a tool-holder, a rocking knurling-tool K having a conical surface, and means for imparting to the tool-holder a longitudinal traveling movement with reference to the axis of the mandrel, while the rocking knurling-  
15 tool is acting on the work.

14. In a knurling-machine, the combination of a rotating mandrel, a reciprocating slide having an independent longitudinal movement with reference to the axis of the  
20 mandrel, a rocking knurling-tool carried thereby, and stops to limit the extreme movement of the reciprocating slide.

15. In a knurling-machine, the combina-

tion of a mandrel a stationary guide-frame arranged longitudinally thereto, a frame ad- 25 justably carried by the longitudinal stationary guide, a slide carried by said frame and movable longitudinally thereon, a second slide movable transversely on the first slide, and a rocking knurling-tool carried by the second 30 slide.

16. In a knurling-machine, the combination with a support for the work to be knurled, and a knurling-tool adapted to be brought in contact with the work on said support, of de- 35 vices for moving the knurling-tool longitudinally with reference to the axis of support for the work and for changing its angular relation with reference thereto.

In testimony of which invention I have 40 hereunto set my hand.

JOSEPH BROWNING.

Witnesses:

ERNEST HOWARD HUNTER,  
C. M. DIETTERICH.